

Multifunction counter board, optically isolated, fast counter inputs - programmable functions, for PCI Express

New!*
10 MHz version

PCI EXPRESS®



Also for **PCI**
see APCI-1710
page 124

Also for **CompactPCI™**
see CPCI-1710
page 188



Signed 64-bit drivers for
Windows 7/Vista/XP



on request



LabVIEW™

The board APCle-1711 is a fast multifunction and multi-channel counter board for the PCI Express bus.

The strengths of this board are its wide range of applications and high precision and reliability in harsh industrial environment.

With this board you can realise many different applications on the same hardware base. The board is supplied with a pool of functions which provides the user with maximum efficiency yet minimum space and parts requirement. The functions are individually configured for each channel through the supplied software. The flexible programming facilities on this board allow many different user applications to be quickly and easily developed and reconfigured as further requirements arise. Thanks to the FPGA board structure, further counting applications can be realised through software adaptation. Contact us!

Features

- 32-bit data access
- RS485 driver with max 5 MHz max. (10 MHz for the APCle-1711-10MHz – without ESD protection)
- With RS485/TTL input/output signals (APCle-1711) or 24 V input signals (APCle-1711-24 V)
- Four onboard function modules

Functions

- Incremental counter for the acquisition of incremental encoders (90° phase-shifted signals)
- BiSS-Master (B and C mode)
- SSI Synchronous Serial Interface. The SSI function is an interface for systems which allow an absolute position information via serial data transfer.
- Counter/timer (82C54)
- Pulse acquisition
- Frequency measurement
- Pulse width modulation (PWM)
- Period duration measurement
- Velocity measurement
- Digital inputs and outputs
- Edge time measurement (ETM)
- Parallel interface
- Customised functions

Available channels on one function module

- 4 channels, programmable either as digital inputs or outputs, optically isolated, RS485
- 3 channels, digital inputs, optically isolated, 24 V
- 1 digital power outputs, optically isolated, 24 V

*Preliminary
product information

APCle-1711

Available functions:

incremental counter, SSI Synchronous Serial Interface, counter/timer, pulse acquisition, frequency, pulse width, period duration, velocity measurement, PWM, BiSS-Master, digital inputs and outputs, ...

Function selection through software

Optical isolation

Inputs and outputs: RS485, TTL, 24 V

Customised functions

Additional channels

- 28 TTL E/A, without optical isolation

Versions

Versions	RS485/ TTL- I/O	24 V inputs	5 V outputs	24 V outputs	TTL I/O
APCle-1711	16	12		4	28
APCle-1711-24V		28		4	28
APCle-1711-5V-I	16		12	4	28
APCle-1711-10MHz	16	12		4	28

Safety features

- Creeping distance IEC 61010-1
- Optical isolation 1000 V
- Noise neutralisation of the PC supply

Applications

- Event counting
- Position acquisition
- Motion control
- Batch counting
- ...

Software drivers

A CD-ROM with the following software and programming samples is supplied with the board.

Standard drivers for:

- 32-bit drivers for Windows 7/Vista/XP/2000/ (real-time)
- Signed 64-bit drivers for Windows 7/Vista/XP

Drivers and samples for the following compilers and software packages:

- Microsoft VC++ • Borland C++

On request:

Further operating systems, compilers and samples.

Driver download: www.addi-data.com, download menu

Wide range of applications through the free combination of functions

4 function modules quickly and easily programmable with numerous functions

Each of the four modules is programmed with one function. You can program 4 times the same function or freely combine 4 different functions.

Configuration example 1			
Function module 0	Function module 1	Function module 2	Function module 3
Incremental counter	Incremental counter	Pulse acquisition	Timer/counter

Configuration example 2			
Function module 0	Function module 1	Function module 2	Function module 3
SSI	SSI	Incremental counter	Digital I/O

Programmable onboard modules

Each module can be programmed with the function of your choice. You can operate simultaneously up to 4 different functions on one board. If your application must be modified, you can load a new function quickly and easily.

Overview of signal generator and functions

Application	Number of signal generator or functions for each function module	Max. use of the function module for each APcLe-1711	Max. number of signal generator or function for each APcLe-1711	Page
Incremental counter	1 (32-bit) or 2 (16-bit)	4	4 or 8	126
SSI	3	4	12	126
Chronos	1	4	4	127
BiSS-Master	6	4	24	92
Counter/Timer	3	4	12	128
TOR	2	4	8	129
Pulse acquisition	4	4	16	130
PWM	2	4	8	130
ETM	2	4	8	131
Digital I/O	8	4	32	131
TTL	24	1	24	131
Parallel interface	1	4	1	92



Customer-tailored modifications, designed to suit your needs. Hardware and software, firmware, PLDs, ... Contact us!

Simplified block diagram

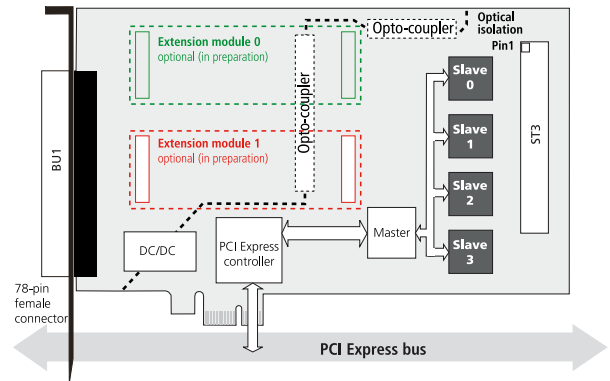

Pin assignment – 78-pin D-Sub female connector

Pin	Pin	Pin	Pin
78 EM0	59 EM0	EM0	39 EM0
77 EM0	58 EM0	EM0	38 EM0
76 EM0	57 EM0	EM0	37 EM1
75 EM1	56 EM0	EM1	36 EM1
74 EM1	55 EM1	EM1	35 EM1
73 EM1	54 EM1	EM1	34 EM1
72 +24V supply	53 EM1	GND	33 E3
71 H3	52 Uref/24Vsupply	F3	32 A3-
70 D3-	51 G3	B3-	31 A3+
69 D3+	50 C3-	B3+	30 A2-
68 H2	49 C3+	F2	29 A2+
67 D2-	48 G2	B2-	28 E1
66 D2+	47 C2-	B2+	27 A1-
65 H1	46 C2+	F1	26 A1+
64 D1-	45 G1	B1-	25 E0
63 D1+	44 C1-	B1+	24 A0-
62 H0	43 C1+	F0	23 A0+
61 D0-	42 G0	B0-	22 A0-
60 D0+	41 C0-	B0+	21 A0+
	40 C0+		GND

EM = Extension module

ADDI-DATA connection

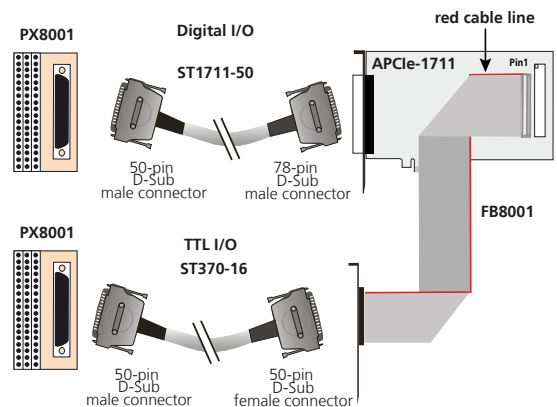

Function parallel interface On request

With the **Parallel Interface** function, the digital inputs of the APCLe-1711 are acquired parallelly. Up to 28 digital inputs, 24 V, can be acquired with the APCLe-1711-24 V. Up to 16 RS422 and 12 24 V digital inputs can be acquired with the APCLe-1711.

There are different methods for the acquisition of the inputs:

- Timer controlled (max. resolution 1 μ s = 1 MHz)
- Digital input (by masking the digital inputs, rising or falling edge)
- Software

This function can be loaded up to 4 times for each APCLe-1711, i.e. it is possible to acquire 8-bit (7 inputs), 16-bit (14 inputs), 24-bit (21 inputs) or 32-bit (28 inputs) parallelly. If an external trigger signal is used (maskable, rising or falling edge) then there is no need to use one of the inputs for triggering.

The data is transferred directly via DMA in the RAM of the PC. If the **Parallel interface** is loaded on all function modules, then up to 28 digital inputs (RS422 / 24 V) are available.

Used signals

On connector	Polarity	Function
Ax +/-	24 V*/ RS485	Digital input
Bx +/-	24 V*/ RS485	Digital input
Cx +/-	24 V*/ RS485	Digital input
Dx +/-	24 V*/ RS485	Digital input
Ex	24 V	Digital input
Fx	24 V	Digital input
Gx	24 V	Digital input

The 24 V switching level can be adjusted optionally down 1 V

x: Number of the module (See pin assignment page 91)

* 24 V for the APCLe-1711-24 V

Block diagram Parallel interface

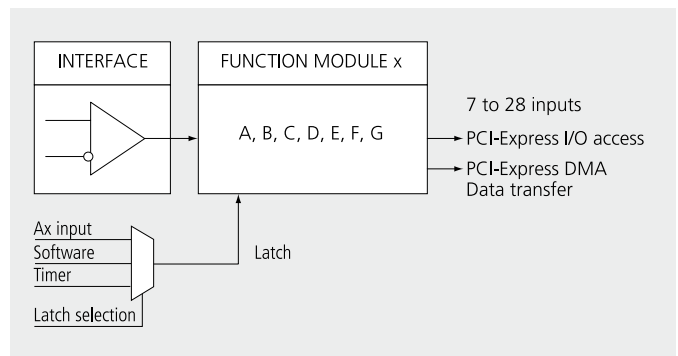

Function BiSS-Master

The **BiSS-Master** function is a bidirectional sensor interface for the communication with up to 6 sensors. BiSS A/B and C are supported.

Features of the BiSS-Master function:

- 1 function module with two channels to which a maximum amount of 6 sensors can be assigned freely.
- Sensor data transmission
- Register data transmission

More information about the function range of the BiSS interface on www.biss-interface.com.

Used signals

Signals	On connector	Polarity	Function
Output0_x	Ax +/-	RS485	Dig. output 0 (clock line from master to slave) MA 0
Input0_x	Bx +/-	RS485	Dig. input 0 (data line from slave to master) SL 0
Output1_x	Cx +/-	RS485	Dig. output 1 (clock line from master to slave) MA 1
Input1_x	Dx +/-	RS485	Dig. input 1 (data line from slave to master) SL 1

x: Number of the module (See pin assignment page 91)

Block diagram BiSS-Master

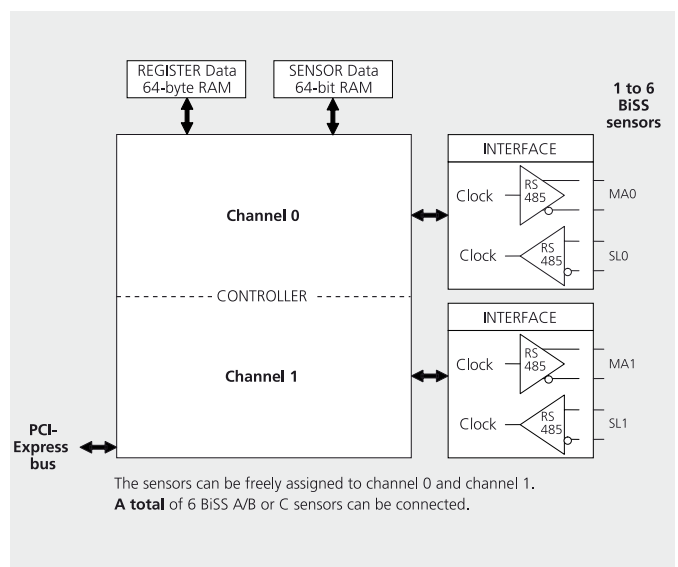

Specifications*

Free programming of the functions

- Acquisition of incremental encoders (1 x 32-bit or 2 x 16-bit)
- SSI (max. 3 encoders per module)
- Counter/timer (3 counters similar to 82C54)
- Pulse counter (4 x 32-bit counters per module)
- Chronos (chronometer)
- TOR (pulse counter with time slices, ...)
- Digital I/O (8 I/O, 24 V, TTL, RS485)
- PWM (pulse width modulation, 2 x per module)
- BiSS-Master (fast sensor interface)
- ETM (Timer interface for period duration measurement, edge time, ...)
- TTL (TTL I/O without isolation)
- Parallel interface
- Customised functions

Signals

Digital I/O signals, TTL or RS485, 24 V

Inputs

Differential inputs or outputs (A, B, C, D)

Differential inputs, RS485:	16 (can be used as inputs or outputs)
Nominal voltage:	3.3 VDC
Common mode range:	+12 / -7 V
Input sensitivity:	200 mV
Input hysteresis:	50 mV
Input impedance:	12 kΩ
Terminal resistor:	120 Ω (not supplied)
Max. input frequency:	APCLe-1711: 5 MHz (at nominal voltage) APCLe-1711-10MHz: 10 MHz (at nominal voltage)

Mass-related inputs, 24 V (channels E, F, G):

Number of inputs:	12
Nominal voltage:	24 VDC
Logic input levels:	Unominal: 24 V UH max.: 30 V UH min.: 18 V UL max.: 16 V UL min.: 0 V

Maximal input frequency: 1 MHz (at nominal voltage) depending on the function

Outputs

Differential inputs or outputs (A, B, C, D)

Nominal voltage:	3.3 VDC
Maximum output frequency:	5 MHz (diff. outputs) depending on the function
Max. number of outputs:	16 (if they are not used as diff. inputs)

Digital outputs, 24 V (H):

Output type:	High-side (load to ground)
Number of outputs:	4
Nominal voltage:	24 VDC
Supply voltage range:	5 V to 30 VDC (via 24 V ext. pin)
Maximum current for 4 outputs:	90 mA per output / 270 mA for all outputs (PTC)
Overtemperature:	165 °C (all 24 V outputs switch off) protection against overtemperature (24 V inputs)

Technical data APCLe-1711-24 V version

24 V inputs (A, B, C, D):

This board version is intended for the connection of 24 V encoders. Only 24 V signals can be connected to the inputs.

Nominal voltage:	24 VDC
Max. input frequency:	1 MHz (at nominal voltage) depending on the function
Logic input levels : (Standard)	Unominal: 24 V UH max.: 30 V UH min.: 18 V UL max.: 16 V UL min.: 0 V

All functions using port A, B, C, D as outputs cannot be used. See the manuals of the functions!

Safety

Optical isolation: 1000 V

EMC – Electromagnetic compatibility

The product complies with the European EMC directive. The tests were carried out by a certified EMC laboratory in accordance with the norm from the EN 61326 series (IEC 61326). The limit values as set out by the European EMC directive for an industrial environment are complied with. The respective EMC test report is available on request.

PC system requirements and environmental conditions

Dimensions:	168 x 98 mm
System bus:	Acc. to PCI Express base specification, Revision 1.0a (PCI Express 1.0a)
Space required:	1-/4-lane PCI Express slot
Operating voltage:	+ 3.3 V / + 12 V from the PC +24 V ext.
Current consumption APCLe-1711:	3.3 V / 340 mA 12 V / 80 mA typ.
Front connector:	78-pin D-Sub female connector
Additional connector:	50-pin D-Sub male connector
Temperature range:	0 to 60 °C (with forced cooling)

APCLe-1711

Multifunction counter board, optically isolated, fast counter inputs – programmable functionality, for PCI Express. Incl. technical description and software drivers.

- APCLe-1711:** Isolated counter board with programmable functionality
- APCLe-1711-24V:** 24 V instead of RS485 (A, B, C, D).
- APCLe-1711-5V-I:** 5 V inputs (E, F, G) instead of 24 V
- APCLe-1711-10MHz:** Input frequency 10 MHz
Inputs (A, B, C, D)

Option

Opt. 5V: 5 V outputs (H1, H2, H3, H4) instead of 24 V

Accessories

- PX8001:** 3-row screw terminal panel with housing for DIN rail
- ST1711-50:** Standard round cable, shielded, twisted pairs, 2 m, 78-pin male connector to 50-pin male connector

For the TTL I/O function

- ST370-16:** Standard round cable, shielded, twisted pairs, 2 m
- FB8001:** Ribbon cable

Ordering information

*Preliminary product information

PCI EXPRESS BOARDS

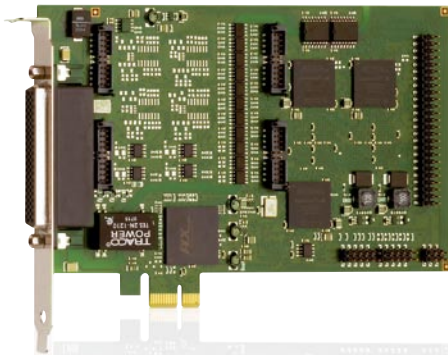

PCI EXPRESS®

YOUR BENEFITS

- Higher data transmission rate
- Shorter cycle times through FPGA technology
- Simplified application design
- Safe operation in an industrial environment
- Long term availability
- Fast upgrade from PCI to PCI Express
- Free loan period.

Prepared for the future

Realise your future PC-based applications with efficient and robust PCI Express boards by ADDI-DATA.

The boards of the APcie-xxxx series are intended for use in an industrial environment: They are equipped with numerous protective circuits like filters, optical isolation, protection against overvoltage and short-circuits, etc. Thus they assure a reliable and smooth operation, particularly in case of dangerous interferences like voltage peaks or high currents.

With the ADDI-DATA PCI Express boards, you secure your investments in the long term.

Simplified application design

ADDI-DATA PCI Express boards come with useful software tools for a fast and convenient integration into your application:

The ingenious driver concept ADDIPACK (see page 79), a wide range of drivers and samples and a configuration tool assist you from the beginning.

Shorter cycle times through FPGA technology

PCI Express boards with FPGA components reduce the cycle time of signal acquisition and regulation tasks. Use the full capacity of your board's hardware and software resources and accelerate your processes. In the product overview, PCI Express boards with FPGA component are indicated.

Upgrade from PCI to PCI Express

Your application is running with ADDI-DATA PCI boards and you would like to upgrade to PCI Express boards? Our PCI Express follow-up models are functionally compatible with our PCI boards. Benefit from the new technologies and the new efficient FPGA components that we have added to our PCI Express boards.

More information about compatibility can be found in the download section on our website www.addi-data.com.

HIGH LEVEL OF PROTECTION

- Optical isolation from 500 V to 1000 V
- Separation of analog and digital signals
- Protection against short-circuits, overtemperature, overvoltage
- Filters for the inputs and outputs
- Industry-standard D-Sub connectors



**READY FOR
HARSH INDUSTRIAL
ENVIRONMENT**

New!

New!



	Digital					Counter	Analog			Watch-dog	Serial Interfaces*	
	APC1e-1502	APC1e-1532	APC1e-1532-12V	APC1e-1516	APC1e-1564		APC1e-2200	APC1e-1711	APC1e-3121 / APC1e-3123			APC1e-3021
PCI Express bus	✓	✓		✓	✓	✓	✓	✓	✓	✓	✓	✓
FPGA	✓	✓		✓	✓	✓	✓	✓	✓	✓	✓	
Filter and protective circuits	✓	✓		✓	✓	✓	✓	✓	✓		✓	✓
Optical isolation	1000 V	1000 V		1000 V	1000 V	1000 V	1000 V	500 V	500 V	500 V	1000 V	optional
Digital, 24 V												
Input channels, incl. interruptible	16 15	16 15		8	32 16	16 15		4 1	4 1	4 1	8	
24 V / 12 V	24 V	24 V 12 V		24 V	24 V	24 V	24 V	24 V	24 V	24 V	24 V	
Output channels, 24 V	16	16		8	16			4	4	4		
Output current per channel	500 mA (typ.)	500 mA (typ.)		500 mA (typ.)	500 mA (typ.)	Relays 2A		65 mA (typ.)	65 mA (typ.)	65 mA (typ.)	Relay 2 A	
Relays						16					8	
Watchdog / Timer / Counter	1 x watchdog/timer, 1 x 12-bit timer, 2 x 16-bit counters	1 x watchdog/timer, 1 x 12-bit timer, 1 x 16-bit counters		watchdog	1 x watchdog/timer, 1 x 12-bit timer, 3 x 16-bit counters	watchdog timer		2x16-bit timers, incl. 1 which can be used as watchdog	1 x 16-bit timer	2x16-bit timers, incl. 1 which can be used as watchdog	7 watchdogs/timers	
Reprogrammable function modules												
– Incremental counter, – SSI synchronous serial interface, – Counter/timer, – Pulse acquisition, – Frequency, pulse width, period duration measurement, PWM – dig. inputs and outputs – BiSS-A/B, BiSS-C – Parallel interface – ...							4					
Input frequency							Up to 5 MHz New: 10 MHz					
Signals							TTL, RS422, 24 V					
Analog												
Analog inputs, 16-bit								16 SE / 8 diff.	16 SE / 8 diff.			
Throughput (kHz)								100	100			
Voltage range								0-10 V ± 10 V	0-10 V ± 10 V			
Current inputs (option)								0(4)-20 mA	0(4)-20 mA			
Gain 1, 2, 5, 10								1, 2, 5, 10	1, 2, 5, 10			
Trigger (software or 24 V)								✓	✓			
Analog outputs, 16-bit								8 or 4		8 or 4		
0-10 V / ± 10 V								✓		✓		
Current outputs								0-20 mA		0-20 mA		
Serial interfaces (base boards)												1 / 2 / 4 / 8 ports
Operating modes configuration through MX modules												RS232, RS422, RS485, 20 mA CL
Software	Current driver list on the web: www.addi-data.com											
Page	82	82	84	86	88	90	94	96	98	100	102	

*Base Boards